

# ARTISTE DAVINCI™

user manual

©2018 **ELATION PROFESSIONAL** all rights reserved. Information, specifications, diagrams, images, and instructions herein are subject to change without notice. ELATION PROFESSIONAL logo and identifying product names and numbers herein are trademarks of ELATION PROFESSIONAL. Copyright protection claimed includes all forms and matters of copyrightable materials and information now allowed by statutory or judicial law or hereinafter granted. Product names used in this document may be trademarks or registered trademarks of their respective companies and are hereby acknowledged. All non-ELATION brands and product names are trademarks or registered trademarks of their respective companies.

**ELATION PROFESSIONAL** and all affiliated companies hereby disclaim any and all liabilities for property, equipment, building, and electrical damages, injuries to any persons, and direct or indirect economic loss associated with the use or reliance of any information contained within this document, and/or as a result of the improper, unsafe, insufficient and negligent assembly, installation, rigging, and operation of this product.

**Elation Professional USA** | 6122 S. Eastern Ave. | Los Angeles, CA. 90040  
323-582-3322 | 323-832-9142 fax | [www.elationlighting.com](http://www.elationlighting.com) | [info@elationlighting.com](mailto:info@elationlighting.com)

**Elation Professional B.V.** | Junostraat 2 | 6468 EW Kerkrade, The Netherlands  
+31 45 546 85 66 | +31 45 546 85 96 fax | [www.elationlighting.eu](http://www.elationlighting.eu) | [info@elationlighting.eu](mailto:info@elationlighting.eu)

**Elation Professional Mexico** | AV Santa Ana 30 | Parque Industrial Lerma, Lerma, Mexico 52000  
+52 (728) 282-7070

## DOCUMENT VERSION

**Due to additional product features and/or enhancements, an updated version of this document may be available online.**

**Please check [www.elationlighting.com](http://www.elationlighting.com) for the latest revision/update of this manual, before beginning installation and/or programming.**

Date	Document Version	Software Version ≥	DMX Channel Modes	Notes
02/09/17	1	1.2.0	26 / 28 / 40	Initial release.
02/20/17	1.2	1.2.1	26 / 28 / 40	Updated Service Setting and Fans Control menu items. Updated dimensional drawings. Added Color & Gobo section.
02/22/17	1.3	N/C	NO CHANGE	Added E-FLY Wireless DMX Section.
09/20/17	1.4	1.2.4	NO CHANGE	Added ArtNet 4 support, Silent Fan Mode, USB Software Update, and multiple System Menu edits.
12/03/18	1.6	N/C	NO CHANGE	Updated release.

# CONTENTS

General Information	4
Limited Warranty (USA Only)	5
Safety Guidelines	6
Maintenance Guidelines	7
Fixture Overview	8
Fixture Installation	9
System Menu	13
E-FLY Wireless DMX Set Up	22
DMX Channel Functions And Values	24
Error Codes	30
Specifications	33
Optional Accessories	35

# GENERAL INFORMATION

## INTRODUCTION

Please read and understand the instructions in this manual carefully and thoroughly before attempting to operate this device. These instructions contain important safety and use information.

## UNPACKING

Every device has been thoroughly tested and has been shipped in perfect operating condition. Carefully check the shipping carton for damage that may have occurred during shipping. If the carton is damaged, carefully inspect the device for damage, and be sure all accessories necessary to install and operate the device have arrived intact. In the event damage has been found or parts are missing, please contact our customer support team for further instructions. Please do not return this device to your dealer without first contacting customer support. Please do not discard the shipping carton in the trash. Please recycle whenever possible.

## BOX CONTENTS

powerCON TRUE1 Cable  
Safety Cable  
Omega Brackets (x2)

## CUSTOMER SUPPORT

Contact ELATION Service for any product related service and support needs. Also visit [forums.elationlighting.com](https://forums.elationlighting.com) with questions, comments or suggestions.

**ELATION SERVICE USA - Monday - Friday 8:00am to 4:30pm PST**  
323-582-3322 | Fax 323-832-9142 | [support@elationlighting.com](mailto:support@elationlighting.com)

**ELATION SERVICE EUROPE - Monday - Friday 08:30 to 17:00 CET**  
+31 45 546 85 63 | Fax +31 45 546 85 96 | [support@elationlighting.eu](mailto:support@elationlighting.eu)

**REPLACEMENT PARTS** please visit [parts.elationlighting.com](https://parts.elationlighting.com)



## IMPORTANT NOTICE !

**THERE ARE NO USER SERVICEABLE PARTS INSIDE THIS UNIT. DO NOT ATTEMPT ANY REPAIRS YOURSELF; DOING SO WILL VOID YOUR MANUFACTURES WARRANTY. DAMAGES RESULTING FROM MODIFICATIONS TO THIS FIXTURE AND/OR THE DISREGARD OF SAFETY INSTRUCTIONS AND GUIDELINES IN THIS MANUAL VOID THE MANUFACTURES WARRANTY AND ARE NOT SUBJECT TO ANY WARRANTY CLAIMS AND/OR REPAIRS.**

## LIMITED WARRANTY (USA ONLY)

A. Elation Professional hereby warrants, to the original purchaser, Elation Professional products to be free of manufacturing defects in material and workmanship for a period of two years (730 days), and Elation Professional product rechargeable batteries to be free of manufacturing defects in material and workmanship for a period of six months (180 days), from the original date of purchase. This warranty excludes discharge lamps and all product accessories. This warranty shall be valid only if the product is purchased within the United States of America, including possessions and territories. It is the owner's responsibility to establish the date and place of purchase by acceptable evidence, at the time service is sought. B. For warranty service, send the product only to the Elation Professional factory. All shipping charges must be pre-paid. If the requested repairs or service (including parts replacement) are within the terms of this warranty, Elation Professional will pay return shipping charges only to a designated point within the United States. If any product is sent, it must be shipped in its original package and packaging material. No accessories should be shipped with the product. If any accessories are shipped with the product, Elation Professional shall have no liability what so ever for loss and/or or damage to any such accessories, nor for the safe return thereof. C. This warranty is void if the product serial number and/or labels are altered or removed; if the product is modified in any manner which Elation Professional concludes, after inspection, affects the reliability of the product; if the product has been repaired or serviced by anyone other than the Elation Professional factory unless prior written authorization was issued to purchaser by Elation Professional; if the product is damaged because not properly maintained as set forth in the product instructions, guidelines and/or user manual. D. This is not a service contract, and this warranty does not include any maintenance, cleaning or periodic check-up. During the periods as specified above, Elation Professional will replace defective parts at its expense, and will absorb all expenses for warranty service and repair labor by reason of defects in material or workmanship. The sole responsibility of Elation Professional under this warranty shall be limited to the repair of the product, or replacement thereof, including parts, at the sole discretion of Elation Professional. All products covered by this warranty were manufactured after January 1, 1990, and bare identifying marks to that effect. E. Elation Professional reserves the right to make changes in design and/or performance improvements upon its products without any obligation to include these changes in any products theretofore manufactured. F. No warranty, whether expressed or implied, is given or made with respect to any accessory supplied with the products described above. Except to the extent prohibited by applicable law, all implied warranties made by Elation Professional in connection with this product, including warranties of merchantability or fitness, are limited in duration to the warranty periods set forth above. And no warranties, whether expressed or implied, including warranties of merchantability or fitness, shall apply to this product after said periods have expired. The consumer's and/or dealer's sole remedy shall be such repair or replacement as is expressly provided above; and under no circumstances shall Elation Professional be liable for any loss and/or damage, direct and/or consequential, arising out of the use of, and/or the inability to use, this product. G. This warranty is the only written warranty applicable to Elation Professional products and supersedes all prior warranties and written descriptions of warranty terms and conditions heretofore published.

### WARRANTY RETURNS

All returned service items whether under warranty or not, must be freight pre-paid and accompany a return authorization (R.A.) number. The R.A. number must be clearly written on the outside of the return package. A brief description of the problem as well as the R.A. number must also be written down on a piece of paper and included in the shipping container. If the unit is under warranty, you must provide a copy of your proof of purchase invoice. Items returned without a R.A. number clearly marked on the outside of the package will be refused and returned at customer's expense. You may obtain a R.A. number by contacting customer support. **ONLY** Use the original packaging and materials to transport the fixture in for service.

# SAFETY GUIDELINES

This fixture is an extremely sophisticated piece of electronic equipment. To guarantee a smooth operation, it is important to follow all instructions and guidelines in this manual. The manufacturer of this device is not responsible for injury and/or damages resulting from the misuse of this fixture due to the disregard of the information printed in this manual. Only qualified and/or certified personnel should perform installation of this fixture and only the original rigging parts (omega brackets) included with this fixture should be used for installation. Any modifications to the fixture and/or the mounting hardware included will void the original manufacturer's warranty and increase the risk of damage and/or personal injury.



## WARNING

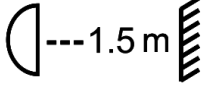

Minimum distance to lighted objects 1.5 meters.  
Maximum temperature of the external surface 85°C.  
Minimum distance of inflammable materials from the surface 0.5m.



**PROTECTION CLASS 1 - FIXTURE MUST BE PROPERLY GROUNDED**

**DO NOT PLUG FIXTURE INTO A DIMMER PACK!**

**NEVER OPEN THIS FIXTURE WHILE IN USE!**



**UNPLUG POWER BEFORE SERVICING FIXTURE!**

**NEVER TOUCH FIXTURE DURING OPERATION, AS IT MAY BE HOT!**

**KEEP FLAMMABLE MATERIALS AWAY FROM FIXTURE!**



**NEVER LOOK DIRECTLY INTO THE LIGHT SOURCE!**

**RETINA INJURY RISK - MAY INDUCE BLINDNESS!**

**SENSITIVE PERSONS MAY SUFFER AN EPILEPTIC SHOCK!**

**DO NOT TOUCH** the fixture housing during operation. Turn OFF the power and allow approximately 15 minutes for the fixture to cool down before serving.

**DO NOT** shake fixture, avoid brute force when installing and/or operating fixture.

**DO NOT** operate fixture if the power cord has become frayed, crimped, damaged and/or if any of the power cord connectors are damaged and do not insert into the fixture securely with ease. **NEVER** force a power cord connector into the fixture. If the power cord or any of its connectors are damaged, replace it immediately with a new one of similar power rating.

**DO NOT** block air ventilation slots. All air/fan inlets must remain clean and never blocked.

Allow approx. 6" (15cm) between fixture and other devices or a wall for proper cooling.

When installing fixture in a suspended environment, always use mounting hardware that is no less than M10 x 25 mm, and always install fixture with an appropriately rated safety cable.

Always disconnect fixture from main power source before performing any type of service and/or cleaning procedure. Only handle the power cord by the plug end, never pull out the plug by tugging the wire portion of the cord.

During the initial operation of this fixture, a light smoke or smell may emit from the interior of the fixture. This is a normal process and is caused by excess paint in the interior of the casing burning off from the heat associated with the lamp and will decrease gradually over time.

Consistent operational breaks will ensure fixture will function properly for many years.

# MAINTENANCE GUIDELINES



**DISCONNECT POWER BEFORE PERFORMING ANY MAINTENANCE!**

## **CLEANING**

Frequent cleaning is recommended to insure proper function, optimized light output, and an extended life. The frequency of cleaning depends on the environment in which the fixture operates: damp, smoky or particularly dirty environments can cause greater accumulation of dirt on the fixture's optics. Clean the external lens surface at least every 20 days with a soft cloth to avoid dirt/debris accumulation.

**NEVER** use alcohol, solvents, or ammonia-based cleaners.

## **MAINTENANCE**

Regular inspections are recommended to insure proper function and extended life.

There are no user serviceable parts inside this fixture, please refer all other service issues to an authorized Elation service technician. Should you need any spare parts, please order genuine parts from your local Elation dealer.

Please refer to the following points during routine inspections:

A detailed electric check by an approved electrical engineer every three months, to make sure the circuit contacts are in good condition and prevent overheating.

Be sure all screws and fasteners are securely tightened at all times. Loose screws may fall out during normal operation resulting in damage or injury as larger parts could fall.

Check for any deformations on the housing, color lenses, rigging hardware and rigging points (ceiling, suspension, trussing). Deformations in the housing could allow for dust to enter into the fixture. Damaged rigging points or unsecured rigging could cause the fixture to fall and seriously injure a person(s).

Electric power supply cables must not show any damage, material fatigue or sediments.

**NEVER** remove the ground prong from the power cable.

# FIXTURE OVERVIEW

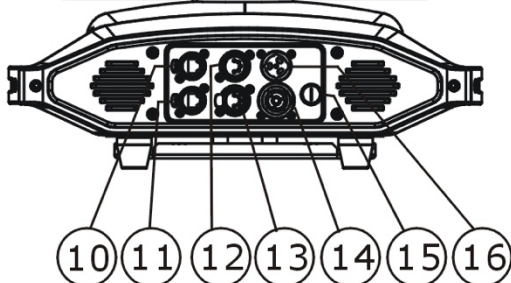
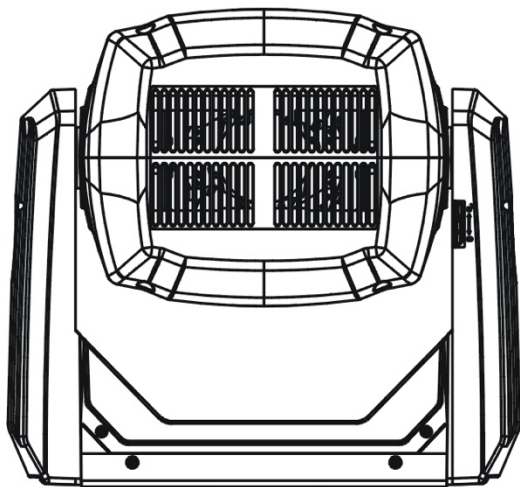
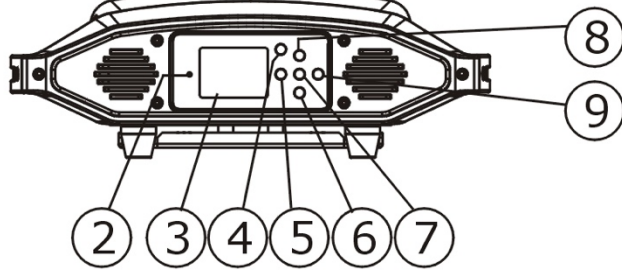
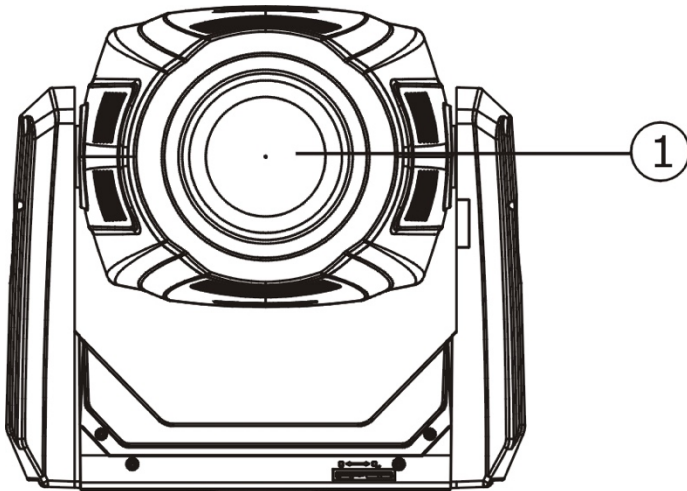

1. LED Lens Array
2. Wireless Indicator
3. LCD Menu Function Display
4. MODE/ESC Button
5. LEFT Button
6. DOWN Button
7. ENTER Button
8. UP Button
9. RIGHT Button
10. RJ45 Ethernet IN
11. RJ45 Ethernet OUT
12. 5pin DMX IN
13. 5pin DMX OUT
14. powerCON TRUE1 OUT
15. Fuse
16. powerCON TRUE1 IN



# FIXTURE INSTALLATION



## WARNING

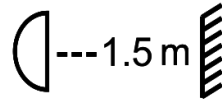

Minimum distance to lighted objects 1.5 meters.  
Maximum temperature of the external surface 85°C.  
Minimum distance of inflammable materials from the surface 0.5m.



### FLAMMABLE MATERIAL WARNING

Keep fixture minimum 5.0 feet (1.5m) away from flammable materials and/or pyrotechnics.



### ELECTRICAL CONNECTIONS

A qualified electrician should be used for all electrical connections and/or installations.



**USE CAUTION WHEN POWER LINKING OTHER MODEL FIXTURES AS THE POWER CONSUMPTION OF OTHER MODEL FIXTURES MAY EXCEED THE MAX POWER OUTPUT ON THIS FIXTURE. CHECK SILK SCREEN FOR MAX AMPS.**



**DO NOT INSTALL THE FIXTURE IF YOU ARE NOT QUALIFIED TO DO SO!**

Fixture **MUST** be installed following all local, national, and country commercial electrical and construction codes and regulations.

Before rigging/mounting the fixture to any metal truss/structure or placing the fixture on any surface, a professional equipment installer **MUST** be consulted to determine if the metal truss/structure or surface is properly certified to safely hold the combined weight of the fixture, clamps, cables, and accessories.

Fixture ambient operating temperature range is **14° to 113°F. (-10° to 45°C)**

Do not use the fixture under or above this temperature.

Fixture should be installed in areas outside walking paths, seating areas, or away from areas where unauthorized personnel might reach the fixture by hand.

**NEVER** stand directly below the fixture when rigging, removing or servicing.

Overhead fixture installation must always be secured with a secondary safety attachment, such as an appropriately rated safety cable.

Allow approximately 15 minutes for the fixture to cool down before serving.

# FIXTURE INSTALLATION

## OMEGA BRACKETS INSTALLATION

Insert the Omega Brackets into the matching holes on the bottom of the fixture. Secure the Omega Brackets to the fixture by turning each quick-lock fastener  $\frac{1}{4}$  turn clockwise; making sure the fastener is completely locked.

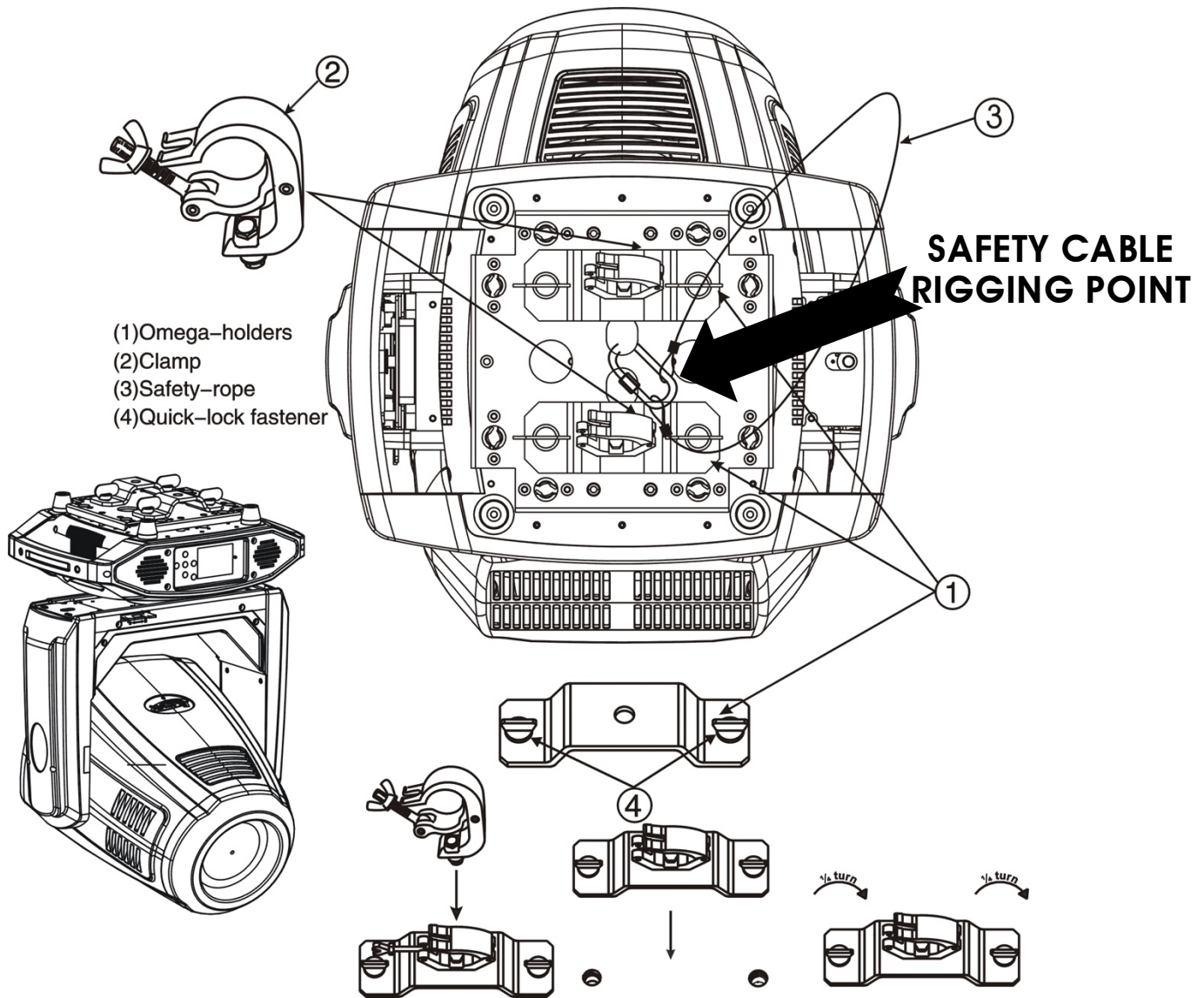

## CLAMP INSTALLATION

When mounting fixture to truss, be sure to secure an appropriately rated professional grade rigging clamp to the included **Omega Brackets** using an M10 screw fitted through the center hole of the **Omega Brackets**. The fixture provides a built-in rigging point for a **SAFETY CABLE**. Be sure to only use the designated rigging point for the safety cable and never secure a safety cable to a carrying handle.

# FIXTURE INSTALLATION

## RIGGING

Overhead rigging requires extensive experience, including amongst others calculating working load limits, installation material being used, and periodic safety inspection of all installation material and the fixture. If you lack these qualifications, do not attempt the installation yourself. Improper installation can result in bodily injury. Fixture is fully operational in the specific mounting positions illustrated below.

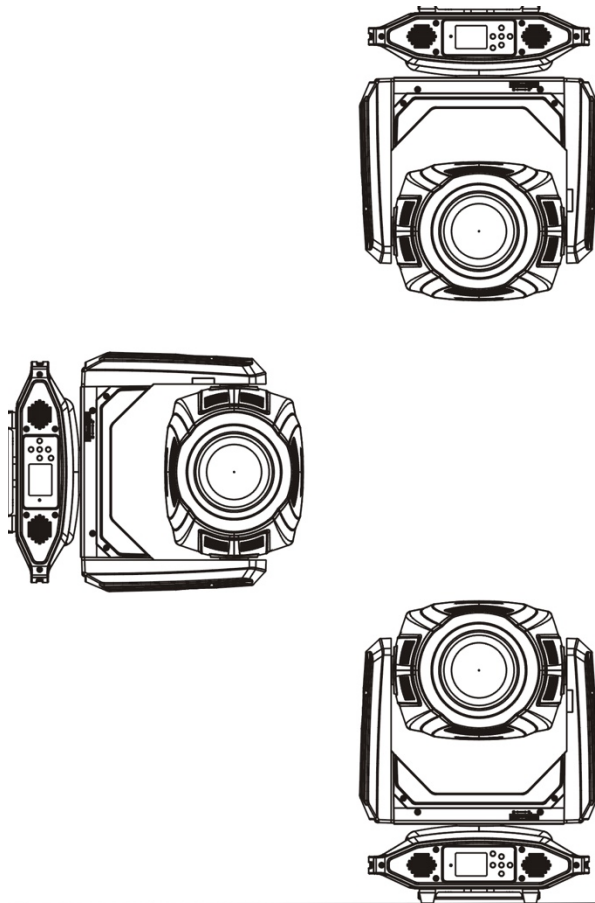

## SAFETY CABLE

**ALWAYS ATTACH A SAFETY CABLE  
WHENEVER INSTALLING THIS FIXTURE  
IN A SUSPENDED ENVIRONMENT TO  
ENSURE THE FIXTURE WILL NOT DROP  
IF THE CLAMP FAILS.**

## ART-NET CONNECTION

When connecting fixture to a network switch to control multiple devices, a **Gigabit Ethernet Switch** that supports **IGMP (Internet Group Management Protocol)** is required. Using a **Gigabit Ethernet Switch** that does not support **IGMP** can cause erratic behavior of all connected devices to the switch.

Click link below for more information about IGMP.

[https://en.wikipedia.org/wiki/Internet\\_Group\\_Management\\_Protocol](https://en.wikipedia.org/wiki/Internet_Group_Management_Protocol)

# FIXTURE INSTALLATION

## POTENTIAL INTERNAL FIXTURE DAMAGE FROM EXTERNAL SOURCES OF LIGHT BEAMS

External sources of light beams from direct sunlight, lighting moving head fixtures, and lasers, which are focused directly towards the exterior housing and/or penetrate the front lens opening of ELATION lighting fixtures, can cause severe internal damage including burning to optics, dichroic color filters, glass and metal gobos, prisms, animation wheels, frost filters, iris, shutters, motors, belts, wiring, discharge lamps, and LEDs.

This issue is not specific only to ELATION lighting fixtures, it is a common issue with lighting fixtures from all manufacturers. Although there is no true way to fully prevent this issue from happening, the guidelines below can prevent any potential damage from occurring if followed. Contact ELATION Service for more details.

**DO NOT EXPOSE THE FIXTURE AND/OR FRONT LENS OPENING TO LIGHT BEAMS FROM DIRECT SUNLIGHT, OTHER LIGHTING MOVING HEAD FIXTURES, AND LASERS WHILE UNPACKING, INSTALLATION, USE, AND EXTENDED IDLE TIMES OUTDOORS.**  
**DO NOT FOCUS A LIGHT BEAM FROM ONE LIGHTING FIXTURE DIRECTLY TOWARDS ANOTHER.**

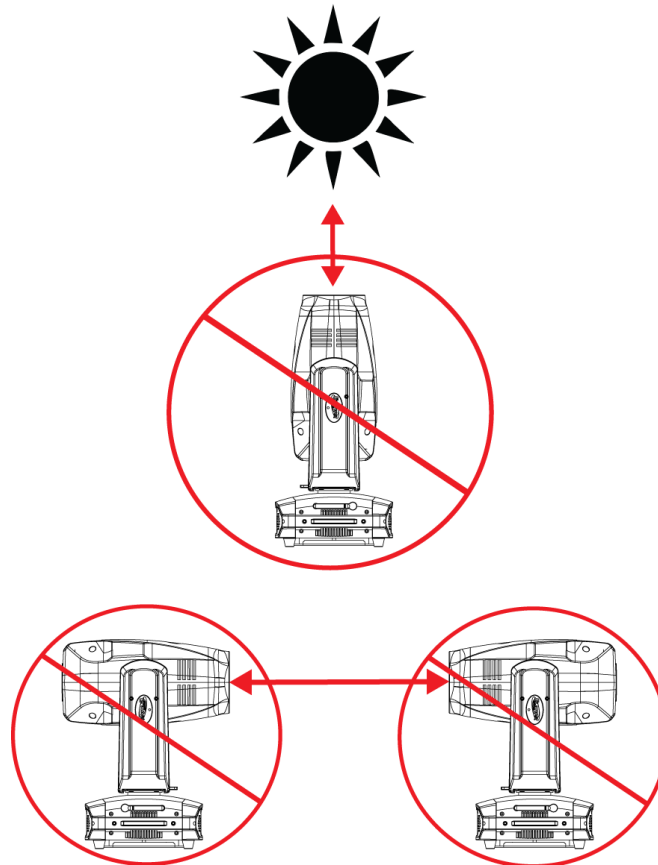

# SYSTEM MENU

The fixture includes an easy to navigate system menu. The control panel (see image below) located on the front of the fixture, provides access to the main system menu and is where all necessary system adjustments are made to the fixture. During normal operation, pressing **MODE/ESC** button once will access the fixture's main menu. Once in the main menu you can navigate through the different functions and access the sub-menus with the **UP, DOWN, RIGHT,** and **LEFT** buttons. Once you reach a field that requires adjusting, press the **ENTER** button to activate that field and use the **UP** and **DOWN** buttons to adjust the field. Pressing the **ENTER** button once more will confirm your setting. You may exit the main menu at any time without making any adjustments by pressing the **MODE/ESC** button.

To access the LCD Menu Control Display via the internal battery, press and hold the **MODE/ESC** button for 3 seconds. The LCD Menu Control Display will shut **OFF** automatically about 1 minute from the last button press.

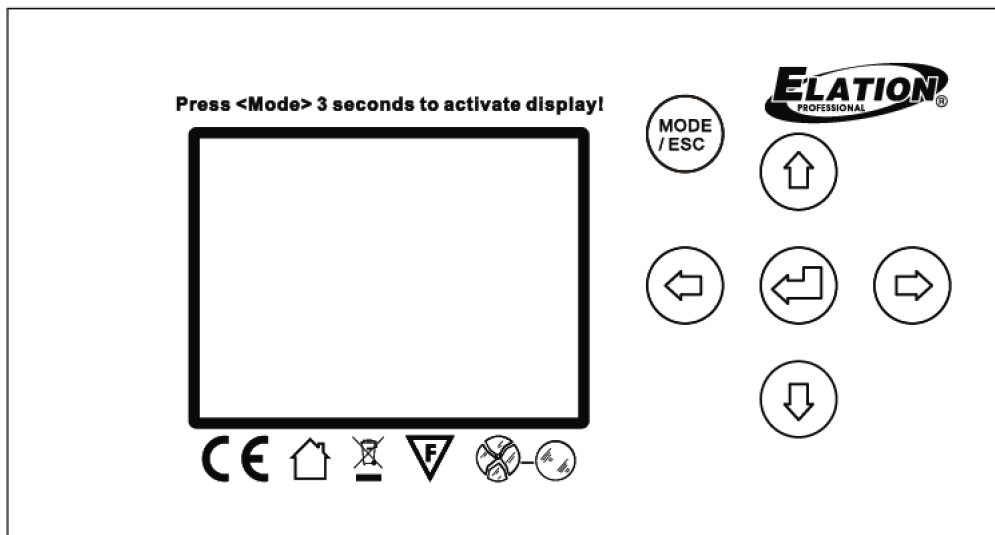

## SYSTEM MENU

Supports Software Versions: ≥ 1.2.0

Features are subject to change without any prior written notice.

\*Rotation direction (Clockwise or Counterclockwise) of effects depends on orientation of the fixture head and Pan/Tilt settings.

MAIN MENU	SUB MENU	OPTIONS / VALUES (Default Settings in <b>BOLD</b> )		DESCRIPTION	
Function	Set Dmx Address	A001~Axxx		DMX Address Setting	
	Dmx Value	ALL.....		DMX Value Display	
	Slave Mode	Slave1, Slave2, Slave3		Slave Setting	
	Auto Program	Master / <b>Alone</b>		Auto Program	
Information	Time Information	Current Time	XXXX (Hours)	Fixture Run Time From Power ON	
		Total Run Time	XXXX (Hours)	Fixture Total Run Time	
		Last Run Time	XXXX (Hours)	Fixture Last Run Time	
		LastRun Password	Password= <b>038</b>	<b>(PSWD Required)</b>	
		Clear Last Run	ON / <b>OFF</b>	Clear Fixture Last Run Time	
	Temperature Info	Head Temperature	XXX C° / <b>F°</b>	Temperature in Fixture Head	
		Base Temperature	XXX C° / <b>F°</b>	Temperature in Fixture Base	
	Ethernet IP	XXX . XXX . XXX . XXX		Displays Fixture Ethernet Address	
	Fan Speed	Head4UFan1 / 2, BaseFan1 / 2		RPM Speeds of Head/Base Fans	
	Software Version	1U01: - 7U01:	≥ <b>V1.2.0</b>	Software Version	
Error Info	Error Record 1 ~ Error Record 10		Fixture Last 10 Error Codes		
Personality	Status Settings	Address via DMX	<b>ON/OFF</b>	Address Via DMX	
		No DMX Status	Close Shutter / <b>Hold</b> / Auto Program	Fixture State When NO DMX Signal	
		Pan Reverse	<b>ON/OFF</b>	Pan Reverse Movement	
		Tilt Reverse	<b>ON/OFF</b>	Tilt Reverse Movement	
		Pan Degree	630/ <b>540</b>	Pan Degree Select	
		Feedback	<b>ON/OFF</b>	Movement Feedback	
		Hibernation	OFF, 01M~99M, <b>15M</b>	Stand By Mode	
	Service Setting	Password	Password= <b>050</b>		Service Password
		RDM PID	<b>22A6xxxxxxxx</b>		RDM PID Code ( <b>PSWD Required</b> )
		Clear Err. Info	<b>ON/OFF</b>		Clear Error Info ( <b>PSWD Required</b> )
		DFLT Pow. WDMXOn	<b>ON/OFF</b>		Set E-FLY Default Power State to ON
		USB	<b>YES/NO</b>		USB Port for Software Updates
	Fans Control	<b>Auto</b> , High, Low		Select Fan Speeds	
	Display Setting	Shutoff Time	02~60m <b>05m</b>	Display Shut Off Time	
		Display Reverse	<b>ON/OFF</b>		Display Reverse 180°
		Key Lock	<b>ON/OFF</b>		Key Lock
	Temperature C/F	<b>Celsius/Fahrenheit</b>		Temperature Switch Between C°/ F°	
	Initial Status	PAN =XXX		Initial Effect Position	
	Select Signal	E-FLY Off			Disable E-FLY Wireless Transceiver
		<b>DMX &amp; E-FLY</b>			Activate 5pin DMX and E-FLY
		E-FLY & OUT			Activate E-FLY and 5pin DMX OUT
		Art-Net on IP2			Activate Art-Net with 002. IP Address
		Art-Net on IP10			Activate Art-Net with 010. IP Address
		sACN			Activate sACN
	Set Universe	<b>000</b> - 255		Set ArtNet Universe	
	Set E-FLY Chn	<b>00</b> - 15		Set E-FLY Wireless Channel	
	Dimmer Mode	<b>Standard</b> , Stage, TV, Architectural, Theatre		Set Dimmer Curve Mode	
	Refresh	1200, 900-1500, 2500, 4000, 5000, 10000, 15000, 20000, 25000 (Hz)		Set LED Refresh Rate Frequency	
	Gamma	2.0, <b>2.2</b> , 2.4, 2.6, 2.8		Set Gamma Brightness	
	Reset Default	<b>ON/OFF</b>	Password= <b>011</b>	Restore Factory Settings ( <b>PSWD Required</b> )	

## SYSTEM MENU

### Supports Software Versions: ≥ 1.2.0

Features are subject to change without any prior written notice.

\*Rotation direction (Clockwise or Counterclockwise) of effects depends on orientation of the fixture head and Pan/Tilt settings.

MAIN MENU	SUB MENU	OPTIONS / VALUES (Default Settings in <b>BOLD</b> )		DESCRIPTION	
Reset Function	Reset All			Reset All Motors	
	Reset Pan&Tilt			Reset Pan/Tilt	
	Reset Colors			Reset Color Wheel	
	Reset Gobos			Reset Gobos	
	Reset Others			Reset Other Motors	
Effect Adjust	Test Channel	PAN .....		Test function	
	Manual Control	PAN =XXX, .....		Fine Adjustments	
	Calibration	Calibration Password		Password <b>050 (PSWD Required)</b>	
User Mode Set	User Mode	<b>Standard Mode</b>		DMX Channel Modes	
		Basic Mode			
		Extended Mode			
	Edit User Mode	User Mode A		User Defined Channel Assignment	
		User Mode B			
		User Mode C			
Edit User Mode	Edit User Mode A	Max Channel = XX PAN = CH01	Edits User Defined Channel Assignments		
	Edit User Mode B				
	Edit User Mode C				
Edit Program	Select Program	Auto Pro Part1 = Program 1~10 ( <b>Program 1</b> )		Select Programs To Be Run	
		Auto Pro Part2 = Program 1~10 ( <b>Program 2</b> )			
		Auto Pro Part3 = Program 1~10 ( <b>Program 3</b> )			
	Edit Program	Program 1	Program Test		Testing Program
		:	Step 01=SCxxx		Program In Loop
		Program 10	Step 64=SCxxx		Save and Exit
	Edit Scenes	Scene 001 ~ Scene 250	Pan,Tilt,.....		Save and Automatically Return
			--Fade Time-- --Scene Time--		Manual Scenes Edit
Input By Outside			Stores Scenes via Ext DMX Console		
Rec. Controller	XX~XX		Automatic Scenes Recorder		

### SYSTEM MENU CHANGE WITH SOFTWARE UPDATE VERSION ≥1.2.1

See highlighted menu items below which have been updated with this software update.

Personality	Service Setting	Password	Password= <b>050</b>	Service Password
		RDM PID	<b>22A6xxxxxxxx</b>	RDM PID Code ( <b>PSWD Required</b> )
		Clear Err. Info	<b>ON/OFF</b>	Clear Error Info ( <b>PSWD Required</b> )
		DFLT Pow. EflyOn	<b>ON/OFF</b>	Set E-FLY Default Power State to ON
		USB	<b>YES/NO</b>	USB Port for Software Updates
Fans Control	<b>Auto, High, Silent</b>		Select Fan Speeds	



## SYSTEM MENU CHANGE WITH SOFTWARE UPDATE VERSION ≥1.2.4

See highlighted menu items below which have been updated with this software update.

INFORMATION	Fan info	Head4UFan1 / 2, BaseFan1 / 2	RPM Speeds of Head/Base Fans	
PERSONALITY	Service Setting	Password	Password= <b>050</b>	Service Password
		RDM UID	<b>22A6xxxxxxxx</b>	RDM PID Code ( <b>PSWD Required</b> )
		Clear Err. Info	ON/ <b>OFF</b>	Clear Error Info ( <b>PSWD Required</b> )
		DFLT Pow. EflyOn	ON/ <b>OFF</b>	Set E-FLY Default Power State to ON
		USB Update	YES/ <b>NO</b>	USB For Fixture Software Updates
	Fans Control	<b>Auto</b> , High, Silent		Select Fan Speeds
	Display Setting	Shutoff Time	02~60m <b>05m</b>	Display Shut Off Time
		Display Reverse	<b>AUTO</b> , ON, OFF	Display Reverse 180°
		Key Lock	ON/ <b>OFF</b>	Key Lock
	Temperature C/F	Celsius/ <b>Fahrenheit</b>		Temperature Switch Between C°/ F°
	Initial Status	PAN =XXX		Initial Effect Position
	Select Signal	E-FLY Off		Disable E-FLY Wireless Transceiver
		<b>DMX &amp; E-FLY</b>		Activate 5pin DMX and E-FLY
		E-FLY & OUT		Activate E-FLY and 5pin DMX OUT
		Art-Net		Select Art-Net
		sACN		Activate sACN
	Ethernet IP	XXX . XXX . XXX . XXX		Ethernet IP (PSWD Required)
Ether Mask IP	XXX . XXX . XXX . XXX		Ethernet Mask IP (PSWD Required)	
Set Universe	<b>000</b> - 32767		Set ArtNet Universe	

### PERSONALITY - Status Settings - Address Via DMX

When ON, define the desired DMX address via an external controller.

**NOTE: This process assumes the fixture DMX address is set to 001. If fixture DMX address is not at 001, you must adjust the channel numbers accordingly in order for this feature to work.**

**For example: if your fixture address is 010, then Channel 1 becomes Channel 10, Channel 2 becomes Channel 11, and Channel 3 becomes Channel 12.**

1. Connect the fixture to the external controller and power ON.
2. Set the DMX value of **Channel 1** on the controller to **(7)**.
3. Set the DMX value of **Channel 2** on the controller to **(7)** or **(8)**.  
When set to **(7)**, the DMX address can be set between **(1)** and **(255)**.  
When set to **(8)**, the DMX address can be set between **(256)** and **(511)**.
4. Using **Channel 3** on the controller set the desired DMX address of the fixture.

**Example 1:** If the desired DMX address is **57**, set **Channel 1** to a value of **(7)**, set **Channel 2** to a value of **(7)**, and then set **Channel 3** to a value of **(57)**.

**Example 2:** If the desired DMX address is **420**, set **Channel 1** to a value of **(7)**, set **Channel 2** to a value of **(8)**, and then set **Channel 3** to a value of **(164)**. (256+164=420)

5. After setting **Channel 3** to the desired DMX address value, wait for approximately 20 seconds (some fixtures may require a longer time) for the fixture to complete the address reset function.



## **PERSONALITY – Service Setting - Password (050)**

The Service Password MUST be entered in order to access the following menus: **RDM PID, Ethernet IP, Ethernet IP Mask, and Clear Err. Info.**

## **PERSONALITY – Service Setting - RDM PID**

Select various submenus via RDM. RDM stands for "Remote Device Management", which provides the ability to control the device remotely while connected to a DMX-bus. ANSI E1.20-2006 by ESTA specifies the RDM standard as an extension of the DMX512 protocol. Manual settings like adjusting the DMX starting address are no longer needed. This is especially useful when the device is installed in a remote area.

RDM ready and conventional DMX devices can be operated in one DMX line. The RDM protocol sends its own packages in the DMX512 data feed and does not influence conventional devices. If DMX splitters are used and RDM control is to be used, these splitters must support RDM. The number and type of RDM parameters depend on the RDM controller being used.

## **PERSONALITY - Display Setting – Key Lock**

When ON, Control Panel buttons lock automatically after exiting main menu for 15 seconds. To unlock, keep **MODE/ESC** button pressed for 3 seconds.

## **PERSONALITY - Select Signal – Art-Net on IP2/IP10 (AVAILABLE ONLY IN SOFTWARE v1.20 & v1.21)**

Fixture has 2 predefined IP addresses for Art-Net. Select **Art-Net on IP2** for a unique 002 IP range address or **Art-Net on IP10** for a unique 010 IP range address.

## PERSONALITY - Dimming Modes

Select desired DIMMER MODE (**Standard**, Stage, TV, Architectural, Theatre).

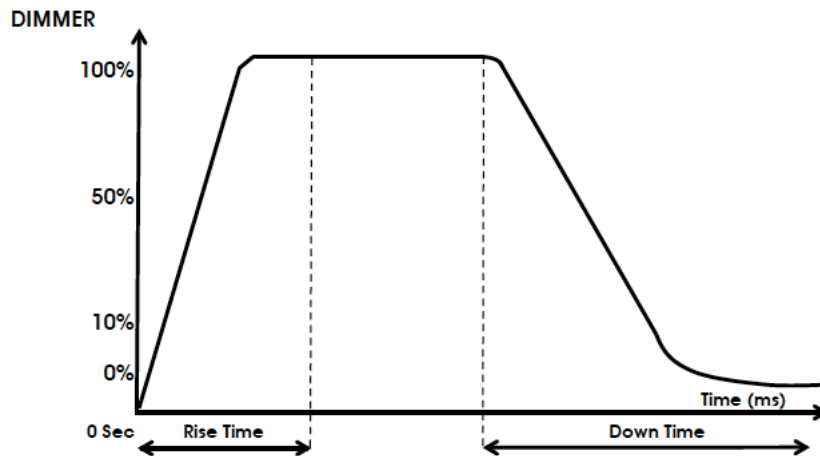

Dimming Curve Ramp Effect	0 sec Fade Time		1 sec Fade Time	
	Rise Time (ms)	Down Time (ms)	Rise Time (ms)	Down Time (ms)
Standard (default)	0	0	0	0
Stage	780	1100	1540	1660
TV	1180	1520	1860	1940
Architectural	1380	1730	2040	2120
Theatre	1580	1940	2230	2280

## PERSONALITY - Reset Default (011)



**ONLY QUALIFIED TECHNICIANS SHOULD PERFORM THIS FUNCTION.**

**SAVED WHITE BALANCE IS ERASED AFTER A RESET IS PERFORMED.**

This function restores all fixture settings to the factory default settings. The password is **011** and must be entered each time a reset is performed.

## EFFECT ADJUST - Test Channel

Auto test each individual channel function independently from the DMX control board.

## EFFECT ADJUST - Manual Control

Select and manually test and fine adjust each individual channel function independently from DMX control board. This function will center PAN and TILT motors and set dimmer to 100%. PAN and TILT functions will still operate if the fixture needs to be positioned to a flat clear surface. With the individual functions, you can focus the light on a flat surface (wall) and perform fine adjustments.

## **EFFECT ADJUST – Calibration**



**ONLY QUALIFIED TECHNICIANS SHOULD PERFORM THIS FUNCTION.**

This function allows small adjustments to be made to the Pan, Tilt, and Zoom movements to compensate for wear or in the event a sensor has been knocked slightly out of place. Because improper use of this function can result in undesired operation this function has been password protected. The password is **050** and must be entered each time the calibration menu function is entered. Because calibration is an extremely delicate procedure, instructions on performing this action are left out of this manual. For a first-time calibrator, please contact our customer support team for step-by-step instructions.

## **USER MODE SET – Edit User Mode**

Create user defined channel orders allowing the fixture to match the channel order of other fixtures on the market for easier operation. A total of three user modes may be configured: User Mode A, User Mode B, and User Mode C.

## **EDIT PROGRAM – Rec. Controller**

The fixture features an integrated DMX-recorder by which you can transmit the programmed scenes from your DMX-controller to the moving head. Adjust the desired scene numbers via the encoder (from – to). When you call up the scenes at your controller, they will automatically be transmitted to the moving head.

## **EDIT PROGRAM – Record Controller – Working With Built In Programs**

A Master unit can send up to 3 different data groups to the Slave units, i.e. a Master unit can start 3 different Slave units, which run 3 different programs. The Master unit sends the 3 program parts in a continuous loop.



The Slave unit receives data from the Master unit according to the group which the Slave unit was assigned to. If e.g. a Slave unit is set to **“Slave 1”** in the menu **“Set to Slave”**, the Master unit sends **“Auto Program Part 1”** to the Slave unit.

If set to **“Slave 2”**, the Slave unit receives **“Auto Program Part 2”**.

## **EDIT PROGRAM – Record Controller – Working with Built-In Program [continued]**

To start an Auto Program, proceed as follows:

### **1. Slave Setting**

- Select **“Function Mode”**.
- Press **ENTER** to confirm.
- Select **“Set to Slave”**.
- Press **ENTER** to confirm.
- Select **“Slave 1”**, **“Slave 2”** or **“Slave 3”**.
- Press **ENTER** to confirm.
- Press **MODE/ESC** in order to return to the main menu.

### **2. Automatic Program Run**

- Select **“Function Mode”**.
- Press **ENTER** to confirm.
- Select **“Auto Program”**.
- Press **ENTER** to confirm.
- Select **“Master”** or **“Alone”**.
- Press **ENTER** to confirm.
- Press **MODE/ESC** in order to return to the main menu.

### **3. Program Selection for Auto Pro Part**

- Select **“Edit Program”**.
- Press **ENTER** to confirm.
- Select **“Select Programs”**.
- Press **ENTER** to confirm.
- Select **“Auto Pro Part 1”**, **“Auto Pro Part 2”** or **“Auto Pro Part 3”**, and select which Slave program is to be sent. Selection **“Part 1”** means, that the Slave unit runs the same program as the master units.
- Press **ENTER** to confirm.
- Press **MODE/ESC** in order to return to the main menu.

## **EDIT PROGRAM – Record Controller – Working with Built-In Program [continued]**

### **4. Program Selection for Edit Program**

- Select “**Edit Program**”.
- Press **ENTER** to confirm.
- Select “**Edit Program**”.
- Press **ENTER** to confirm.
- Select the desired program to edit specific scenes into a specific program.
- Press **ENTER** to confirm.
- Press **MODE/ESC** in order to return to the main menu.

### **5. Automatic Scene Recording**

- Select “**Edit Program**”.
- Press **ENTER** to confirm.
- Select “**Edit Scenes**”.
- Select desired scene numbers. A maximum of 250 scenes can be programmed.
- Press **ENTER** to confirm.
- Press **MODE/ESC** in order to return to the main menu.

#### **Example:**

Program 2 includes scenes: 10, 11, 12, & 13

Program 4 includes scenes: 8, 9, & 10

Program 6 includes scenes: 12, 13, 14, & 15

Auto Pro Part 1 is Program 2

Auto Pro Part 2 is Program 3

Auto Pro Part 3 is Program 6

The 3 Slave groups run the Auto Program in certain time segments. (See diagram below)

Part 1:

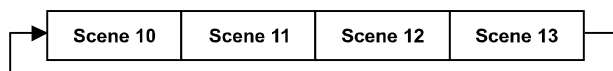

Part 2:

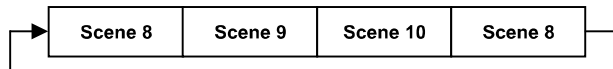

Part 3:

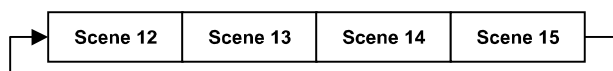

# E - FLY WIRELESS DMX SET UP



**BEFORE SETTING THE WIRELESS CHANNEL ON ANY E-FLY FIXTURE, MAKE SURE THE SOURCE E-FLY WIRELESS DMX TRANSCEIVER DEVICE IS OFF.**

## TO CONTROL FIXTURE WITH E-FLY WIRELESS DMX SIGNAL

1. Ensure the source **E-FLY** wireless DMX Transceiver device is powered **OFF**.
2. Power **ON** fixture and from the LCD control panel select **DMX & E-FLY** or **E-FLY & OUT** in the **Select Signal** sub menu of the **PERSONALITY** main system menu.
3. From the LCD control panel set the **E-FLY** wireless channel to the same wireless channel of the source **E-FLY** DMX Transceiver device in the **Set E-FLY Chn** sub menu of the **PERSONALITY** main system menu.



**NOTE:** Erratic fixture movement may occur if other **E-FLY** wireless DMX products are in use in the same area and are using the same **E-FLY** wireless channel. The fixture may immediately start to respond to the DMX wireless signal from another **E-FLY** wireless DMX Transceiver immediately when **E-FLY** is enabled. Make sure to know what **E-FLY** wireless channels are being used in the area where the fixture is being installed.

**ELATION E-FLY WIRELESS TRANSCEIVER only has 0-14 wireless channels, NO CH 15.**

4. Set fixture DMX address in the **Set Dmx Address** sub menu of the **FUNCTION** main system menu.
5. The **E-FLY** signal Indicator on the fixture LCD control display will illuminate **GREEN** if a successful wireless DMX connection has been made or illuminate **RED** for NO connection. If no connection is made, repeat steps 1-4 above.
6. Repeat this process for all **E-FLY** compatible fixtures in the E-FLY wireless network, making sure all fixtures are assigned the same **E-FLY** wireless channel.
7. After all fixtures in the **E-FLY** wireless network have been set to the same **E-FLY** wireless channel and powered ON, now power ON the source **E-FLY** DMX Transceiver device.
8. Test all fixtures connected to the **E-FLY** wireless network to confirm proper functionality.

## **WIRELESS E-FLY INSTALLATION LOCATION GUIDELINES**

Wireless DMX signal can penetrate walls, glass, metal, and most objects. However, there are many factors that can affect and/or interrupt the wireless DMX signal, one of which is people. Therefore, it is highly recommended to position the wireless antenna a minimum of 9.8 ft. (3m) above audiences and/or above ground level. Careful planning and testing of the selected installation location is critical to ensure optimum and reliable wireless DMX operation.

**9.8 ft (3m)  
Above Ground**

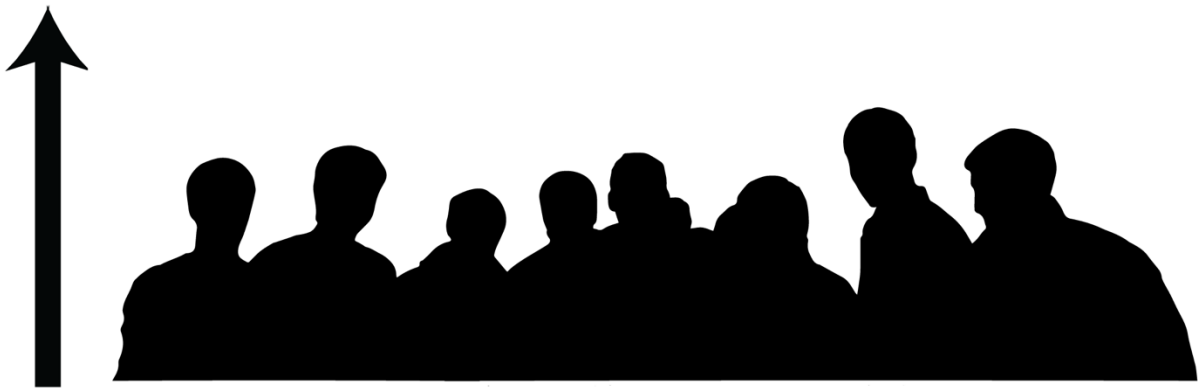

# DMX CHANNEL FUNCTIONS AND VALUES

## RELATION ARTISTE DAVINCI

DMX Channel Values / Functions (40 DMX Channels)

**Supports Software Versions: ≥ 1.2.0**

Features are subject to change without any prior written notice.

\*Rotation direction (Clockwise or Counterclockwise) of effects depends on orientation of the fixture head and Pan/Tilt settings.

MODE / CHANNEL			VALUE	FUNCTION
BASIC	STANDARD	EXTENDED		
1	1	1		PAN MOVEMENT
			0-255	PAN Movement
	2	2		PAN FINE MOVEMENT [16 BIT]
			0-255	Fine Control of PAN Movement
2	3	3		TILT MOVEMENT
			0-255	TILT Movement
	4	4		TILT MOVEMENT [16 BIT]
			0-255	Fine Control of TILT Movement
3	5	5		CYAN COLOR
			0-255	0-WHITE ~ 255-100% CYAN
		6		CYAN COLOR FINE [16 BIT]
			0-255	CYAN FINE Adjustment
4	6	7		MAGENTA COLOR
			0-255	0-WHITE ~ 255-100% MAGENTA
		8		MAGENTA COLOR FINE [16 BIT]
			0-255	MAGENTA FINE Adjustment
5	7	9		YELLOW COLOR
			0-255	0-WHITE ~ 255-100% YELLOW
		10		YELLOW COLOR FINE [16 BIT]
			0-255	YELLOW FINE Adjustment
6	8	11		CTO COLOR
			0-255	0-WHITE ~ 255-100% CTO
		12		CTO COLOR FINE [16 BIT]
			0-255	CTO FINE Adjustment
7	9	13		COLOR WHEEL
			0-15	OPEN / WHITE
			16-31	RED
			32-47	BLUE
			48-63	GREEN
			64-79	LIGHT YELLOW
			80-95	HALF MINUS GREEN
			96-111	CTB
			112-127	VIOLET
			128-189	*Clockwise COLOR Rotation from FAST to SLOW
			190-193	NO Rotation
194-255	*Counterclockwise COLOR Rotation from SLOW to FAST			
		14		COLOR WHEEL FINE ADJUSTMENT [16 BIT]
			0-255	FINE Adjustment of Color Wheel to Any Position



**Supports Software Versions: ≥ 1.2.0**

Features are subject to change without any prior written notice.

\*Rotation direction (Clockwise or Counterclockwise) of effects depends on orientation of the fixture head and Pan/Tilt settings.

MODE / CHANNEL			VALUE	FUNCTION
BASIC	STAND	EXTEN D		
8	10	15		<b>ROTATING GOBOS, CONTINUOUS ROTATION [GOBO WHEEL 1]</b>
			0-9	OPEN
			10-19	Rotating Gobo 1
			20-29	Rotating Gobo 2
			30-39	Rotating Gobo 3
			40-49	Rotating Gobo 4
			50-59	Rotating Gobo 5
			60-69	Rotating Gobo 6
			70-89	Gobo 1 Shake SLOW to FAST
			90-109	Gobo 2 Shake SLOW to FAST
			110-129	Gobo 3 Shake SLOW to FAST
			130-149	Gobo 4 Shake SLOW to FAST
			150-169	Gobo 5 Shake SLOW to FAST
			170-189	Gobo 6 Shake SLOW to FAST
			190-221	*Clockwise Gobo Wheel Rotation from FAST to SLOW
222-223	RESERVED			
224-255	*Counterclockwise Gobo Wheel Rotation from SLOW to FAST			
9	11	16		<b>ROTATING GOBOS, INDEX ROTATION [GOBO WHEEL 1]</b>
			0-127	Gobo Indexing
			128-189	*Clockwise Gobo Rotation from FAST TO SLOW
			190-193	NO Rotation
			194-255	*Counterclockwise Gobo Rotation from SLOW to FAST
		17		<b>ROTATING GOBOS, FINE INDEX ROTATION [GOBO WHEEL 1] [16 BIT]</b>
			0-255	Gobo Rotation FINE Indexing
10	12	18		<b>STATIC / FIXED GOBOS [GOBO WHEEL 2]</b>
			0-9	OPEN
			10-19	Static / Fixed Gobo 1
			20-29	Static / Fixed Gobo 2
			30-39	Static / Fixed Gobo 3
			40-49	Static / Fixed Gobo 4
			50-59	Static / Fixed Gobo 5
			60-69	Static / Fixed Gobo 6
			70-79	Static / Fixed Gobo 7
			80-89	Static / Fixed Gobo 8
			90-99	Static / Fixed Gobo 9
			100-109	Shake SLOW to FAST Static / Fixed Gobo 1
			110-119	Shake SLOW to FAST Static / Fixed Gobo 2
			120-129	Shake SLOW to FAST Static / Fixed Gobo 3
			130-139	Shake SLOW to FAST Static / Fixed Gobo 4
			140-149	Shake SLOW to FAST Static / Fixed Gobo 5
			150-159	Shake SLOW to FAST Static / Fixed Gobo 6
			160-169	Shake SLOW to FAST Static / Fixed Gobo 7
			170-179	Shake SLOW to FAST Static / Fixed Gobo 8
			180-189	Shake SLOW to FAST Static / Fixed Gobo 9
190-221	*Clockwise Gobo Wheel Rotation from FAST to SLOW			
222-223	NO FUNCTION			
224-255	*Counterclockwise Gobo Wheel Rotation from SLOW to FAST			

## Supports Software Versions: ≥ 1.2.0

Features are subject to change without any prior written notice.

\*Rotation direction (Clockwise or Counterclockwise) of effects depends on orientation of the fixture head and Pan/Tilt settings.

MODE / CHANNEL			VALUE	FUNCTION
BASIC	STAND	EXTEND		
		19		<b>STATIC / FIXED GOBOS, FINE INDEX ROTATION [GOBO WHEEL 2] [16 BIT]</b>
			0-255	Gobo Rotation FINE Indexing
				<b>ROTATING PRISM, PRISM / GOBO MACROS</b>
			0-31	OPEN
			32-79	3-FACET PRISM
			80-127	LINEAR PRISM
			128-135	Prism / Gobo Macro 1
			136-143	Prism / Gobo Macro 2
			144-151	Prism / Gobo Macro 3
			152-159	Prism / Gobo Macro 4
			160-167	Prism / Gobo Macro 5
			168-175	Prism / Gobo Macro 6
			176-183	Prism / Gobo Macro 7
			184-191	Prism / Gobo Macro 8
			192-199	Prism / Gobo Macro 9
			200-207	Prism / Gobo Macro 10
			208-215	Prism / Gobo Macro 11
			216-223	Prism / Gobo Macro 12
			224-231	Prism / Gobo Macro 13
			232-239	Prism / Gobo Macro 14
			240-247	Prism / Gobo Macro 15
			248-255	Prism / Gobo Macro 16
				<b>ROTATING PRISM, PRISM INDEX ROTATION</b>
			0-127	Prism Indexing
			128-189	*Clockwise Prism Rotation from FAST to SLOW
			190-193	NO Rotation
			194-255	*Counterclockwise Prism Rotation from SLOW to FAST
		22		<b>ROTATING PRISM, PRISM FINE INDEX ROTATION [16 BIT]</b>
			0-255	Gobo Rotation FINE Indexing
				<b>FOCUS</b>
			0-255	Continuous Adjustment from NEAR to FAR
				<b>FOCUS FINE [16 BIT]</b>
			0-255	Continuous FINE Focus Adjustment
				<b>MOTORIZED ZOOM</b>
			0-255	ZOOM Adjustment from SMALL to BIG
				<b>MOTORIZED ZOOM FINE [16 BIT]</b>
			0-255	ZOOM FINE Adjustment
				<b>AUTO FOCUS</b>
			0-50	AUTO FOCUS OFF
			51-150	49.2 ft (15m)
			151-255	65.6 ft (20m)
				<b>AUTO FOCUS FINE</b>
			0-255	Continuous FINE Focus Adjustment
11	13	20		
12	14	21		
13	15	23		
14	16	25		
15	17	27		
16	18	28		

## Supports Software Versions: ≥ 1.2.0

Features are subject to change without any prior written notice.

\*Rotation direction (Clockwise or Counterclockwise) of effects depends on orientation of the fixture head and Pan/Tilt settings.

MODE / CHANNEL			VALUE	FUNCTION
BASIC	STAND	EXTEND		
17	19	29		<b>SHUTTER, STROBE</b>
			0-31	Shutter CLOSED
			32-63	NO Function (Shutter OPEN)
			64-95	Strobe Effect SLOW to FAST
			96-127	NO function (Shutter OPEN)
			128-159	Pulse Effect In Sequences
			160-191	NO Function (Shutter OPEN)
			192-223	Random Strobe Effect SLOW to FAST
		224-255	NO Function (Shutter OPEN)	
18	20	30		<b>DIMMER INTENSITY</b>
			0-255	Intensity 0 to 100%
		31		<b>DIMMER INTENSITY FINE [16 BIT]</b>
			0-255	Intensity 0 to 100%
19	21	32		<b>DIMMER CURVE MODES</b>
			0-20	STANDARD
			21-40	STAGE
			41-60	TV
			61-80	ARCHITECTURAL
			81-100	THEATER
		101-255	DEFAULT to UNIT CURVE SETTING	
20	22	33		<b>IRIS</b>
			0-191	MAX to MIN Diameter
			192-223	Pulse Closing FAST to SLOW
			224-255	Pulse Closing SLOW to FAST
		34		<b>IRIS FINE</b>
			0-255	Iris FINE Adjustment
21	23	35		<b>FROST</b>
			0-255	NO Frost to FULL Frost
22	24	36		<b>ANIMATION WHEEL</b>
			0-7	OPEN
			8-127	*Clockwise Animation Wheel Rotation from FAST to SLOW
			128-135	NO Rotation
		136-255	*Counterclockwise Animation Wheel Rotation from SLOW to FAST	

## Supports Software Versions: ≥ 1.2.0

Features are subject to change without any prior written notice.

\*Rotation direction (Clockwise or Counterclockwise) of effects depends on orientation of the fixture head and Pan/Tilt settings.

MODE / CHANNEL			VALUE	FUNCTION
BASIC	STAND	EXTEND		
23	25	37		<b>CMY / COLOR MACRO SPEED</b>
			0-255	MAX to MIN Speed
24	26	38		<b>CMY / COLOR MACROS</b>
			0-31	OFF
			32-39	Macro 1
			40-47	Macro 2
			48-55	Macro 3
			56-63	Macro 4
			64-71	Macro 5
			72-79	Macro 6
			80-87	Macro 7
			88-95	Macro 8
			96-103	Macro 9
			104-111	Macro 10
			112-119	Macro 11
			120-127	Macro 12
			128-135	Macro 13
			136-143	Macro 14
			144-151	Macro 15
			152-159	Macro 16
			160-167	Macro 17
			168-175	Macro 18
			176-183	Macro 19
			184-191	Macro 20
			192-199	Macro 21
			200-207	Macro 22
208-215	Macro 23			
216-223	Macro 24			
224-231	Macro 25			
232-239	Macro 26			
240-247	Macro 27			
248-255	RANDOM CMY			
25	27	39		<b>PAN / TILT MOVEMENT SPEED</b>
			0-225	MAX to MIN Speed
			226-235	Blackout by Movement
			236-245	Blackout by ALL Wheel Movement
			246-255	NO FUNCTION

## Supports Software Versions: ≥ 1.2.0

Features are subject to change without any prior written notice.

\*Rotation direction (Clockwise or Counterclockwise) of effects depends on orientation of the fixture head and Pan/Tilt settings.

MODE / CHANNEL			VALUE	FUNCTION
BASIC	STAND	EXTEND		
26	28	40		LAMP ON/OFF, RESET, INTERNAL PROGRAMS
			0-19	COLOR Change Normal
			20-29	COLOR Change to Any Position
			30-39	COLOR & GOBO Change to Any Position
			40-59	NO FUNCTION
			60-79	NO FUNCTION
			80-84	ALL Motors Reset
			85-87	SCAN Motor Reset
			88-90	COLOR Motors Reset
			91-93	GOBO Motors Reset
			94-96	NO FUNCTION
			97-99	OTHER Motors Reset
			100-119	Internal Program 1
			120-139	Internal Program 2
			140-159	Internal Program 3
			160-179	Internal Program 4
			180-199	Internal Program 5
			200-219	Internal Program 6
220-239	Internal Program 7			
240-255	RESERVED			

## **E R R O R   C O D E S**

When power is applied, the unit will automatically enter a **“Reset/Test”** mode. This mode brings all the internal motors to a home position. If there is an internal problem with one or more of the motors an error code will flash in the display in the form of **“XXer”** where as XX will represent a function number. For example, when the display shows **“0Er”** it means there is some type of error with the Pan motor. If there are multiple errors during the start-up process they will all flash in the display. For example: if the fixtures has errors on **Channel 1, 2, and 5** all at the same time, you will see the error message **“01Er”, “02Er”, and “05Er”** flash repeated 5 times.

If an error does occur during the initial start-up procedure the fixture will self-generate a second reset signal and try to realign all the motors and correct the errors. If the error persists after a second attempt a third attempt will be made. If after a third attempt all the errors have not been corrected the fixture will make the following determinations:

- **3 or More Errors** - The fixture cannot function properly with three or more errors therefore the fixture will place itself in a stand-by mode until subsequent repairs can be made.
- **Less Than 3 Errors** - The fixture has less than 3 errors; therefore most other functions will work properly. The fixture will attempt to operate normally until the errors can be correct by a technician. The errors in question will remain flashing in the display as a reminder of internal errors.

## ELATION ARTISTE DAVINCI ERROR CODES

Error Codes are subject to change without any prior written notice.

ERROR CODE	DESCRIPTION
<b>PAN</b>	The PAN movement is not located in the default position after the reset. This message will appear after a fixture reset if the magnetic-indexing circuit malfunctions (sensor failed or magnet is missing) or there is a motor failure (defective motor or a defective motor IC drive on the main PCB). This error may also be displayed if the head/yoke was blocked during a reset function.
<b>TILT</b>	The TILT movement is not located in the default position after the reset. This message will appear after a fixture reset if the magnetic-indexing circuit malfunctions (sensor failed or magnet is missing) or there is a motor failure (defective motor or defective motor IC drive on main PCB). This error may also be displayed if the head was blocked during a reset function.
<b>CMY</b>	The CMY movement is not located in the default position after the reset. This message will appear after a fixture reset if the magnetic-indexing circuit malfunctions (sensor failed or magnet is missing) or there is a motor failure (defective motor or defective motor IC drive on main PCB).
<b>CTO</b>	The CTO movement is not located in the default position after the reset. This message will appear after a fixture reset if the magnetic-indexing circuit malfunctions (sensor failed or magnet is missing) or there is a motor failure (defective motor or defective motor IC drive on main PCB).
<b>COLOR</b>	The COLOR wheel movement is not located in the default position after the reset. This message will appear after a fixture reset if the magnetic-indexing circuit malfunctions (sensor failed or magnet is missing) or there is a motor failure (defective motor or defective motor IC drive on main PCB).
<b>GOBO</b>	The GOBO1 wheel movement is not located in the default position after the reset. This message will appear after a fixture reset if the magnetic-indexing circuit malfunctions (sensor failed or magnet is missing) or there is a motor failure (defective motor or defective motor IC drive on main PCB).
<b>GOBO_R</b>	The GOBO1_R movement is not located in the default position after the reset. This message will appear after a fixture reset if the magnetic-indexing circuit malfunctions (sensor failed or magnet is missing) or there is a motor failure (defective motor or defective motor IC drive on main PCB).
<b>GOBO2</b>	The GOBO2 wheel movement is not located in the default position after the reset. This message will appear after a fixture reset if the magnetic-indexing circuit malfunctions (sensor failed or magnet is missing) or there is a motor failure (defective motor or defective motor IC drive on main PCB).
<b>3_PRISM</b>	The 3 PRISM wheel movement is not located in the default position after the reset. This message will appear after a fixture reset if the magnetic-indexing circuit malfunctions (sensor failed or magnet is missing) or there is a motor failure (defective motor or defective motor IC drive on main PCB).
<b>3_Prism1Rot</b>	The 3 Prism1Rot movement is not located in the default position after the reset. This message will appear after a fixture reset if the magnetic-indexing circuit malfunctions (sensor failed or magnet is missing) or there is a motor failure (defective motor or defective motor IC drive on main PCB).
<b>Line_PRISM</b>	The Line_PRISM wheel movement is not located in the default position after the reset. This message will appear after a fixture reset if the magnetic-indexing circuit malfunctions (sensor failed or magnet is missing) or there is a motor failure (defective motor or defective motor IC drive on main PCB).
<b>Line_Prism1Rot</b>	The Line_Prism1Rot movement is not located in the default position after the reset. This message will appear after a fixture reset if the magnetic-indexing circuit malfunctions (sensor failed or magnet is missing) or there is a motor failure (defective motor or defective motor IC drive on main PCB).
<b>FOCUS</b>	The FOCUS movement is not located in the default position after the reset. This message will appear after the reset of the fixture reset if the magnetic-indexing circuit malfunctions (sensor failed or magnet is missing) or there is a stepper motor failure (defective motor or defective motor IC drive on main PCB).

**ELATION ARTISTE DAVINCI  
ERROR CODES**

Error Codes are subject to change without any prior written notice.

<b>ERROR CODE</b>	<b>DESCRIPTION</b>
<b>ZOOM</b>	The ZOOM movement is not located in the default position after the reset. This message will appear after the reset of the fixture reset if the magnetic-indexing circuit malfunctions (sensor failed or magnet is missing) or there is a stepper motor failure (defective motor or defective motor IC drive on main PCB).
<b>IRIS</b>	The IRIS movement is not located in the default position after the reset. This message will appear after the reset of the fixture reset if the magnetic-indexing circuit malfunctions (sensor failed or magnet is missing) or there is a stepper motor failure (defective motor or defective motor IC drive on main PCB).
<b>FROST</b>	The FROST movement is not located in the default position after the reset. This message will appear after a fixture reset if the magnetic-indexing circuit malfunctions (sensor failed or magnet is missing) or there is a motor failure (defective motor or defective motor IC drive on main PCB).
<b>ANIMATION</b>	The ANIMATION wheel movement is not located in the default position after the reset. This message will appear after a fixture reset if the magnetic-indexing circuit malfunctions (sensor failed or magnet is missing) or there is a motor failure (defective motor or defective motor IC drive on main PCB).
<b>AnimationRot</b>	The ANIMATIONRot movement is not located in the default position after the reset. This message will appear after a fixture reset if the magnetic-indexing circuit malfunctions (sensor failed or magnet is missing) or there is a motor failure (defective motor or defective motor IC drive on main PCB).



# SPECIFICATIONS

## SOURCE

270W Cool White 12,000 Lumen LED Engine

30,000 Hour Average LED Life\*

\*May vary depending on several factors including but not limited to:  
Environmental Conditions, Power/Voltage, Usage Patterns (On-Off Cycling), Control, and Dimming.

## EFFECTS

Motorized Zoom

3-Facet and Linear Rotating Prisms and Prism Macros

Bi-Directional Full 360° Rotating Animation Wheel

Frost Filter Hybrid Wash Effect

Motorized Zoom, Iris, Focus, and Auto-Focus

High Speed Electronic Shutter and Strobe

16-Bit Variable Dimming Curve Modes

Variable LED Refresh Rate and Gamma Brightness

## COLOR

7 Dichroic Colors including CTB

Full CMY Color Mixing

Linear CTO Color Correction

## GOBOS

(2) Gobo Wheels

(6) Interchangeable-Rotating / Indexing Glass Gobos

(9) Interchangeable Static-Stamped Metal Gobos

## CONTROL / CONNECTIONS

(3) DMX Channel Modes (40 Total Channels)

6 Button Touch Control Panel

Full Color 180° Reversible LCD Menu Display

8 / 16 Bit Resolution Adjustable Movement

DMX, RDM (Remote Device Management), Art-NET, sACN Protocol Support

Elation E-FLY™ Internal Wireless DMX Transceiver

5pin DMX In/Out

RJ45 Ethernet In/Out (Art-NET)

powerCON TRUE1 Power In/Out

## SIZE / WEIGHT

Length: 16.4" (416mm)

Width: 11.2" (284mm)

Vertical Height: 25.4" (645mm)

Weight: 56.0 lbs. (25.4 kg)

## ELECTRICAL / THERMAL

AC 100-240V - 50/60Hz

470W Max Power Consumption

14°F to 113°F (-10°C to 45°C)

## APPROVALS / RATINGS

CE | IP20 |    
 Intertek   
 4010832

Specifications and improvements in the design of this unit and this manual are subject to change without any prior written notice.

## COLORS & GOBOS

### COLOR FLAGS



### COLOR WHEEL



### INTERCHANGEABLE-ROTATING GOBO WHEEL 1 - OD: Ø29.8mm\*\* ID: Ø20.0mm

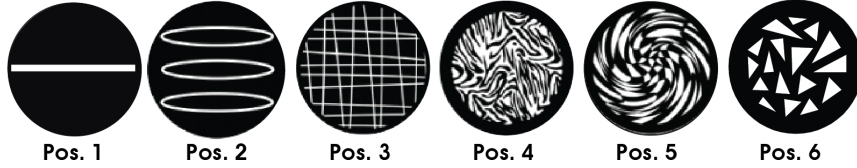

### INTERCHANGEABLE STATIC-FIXED GOBO WHEEL 2 - OD: Ø25.8mm\*\* ID: Ø22.0mm

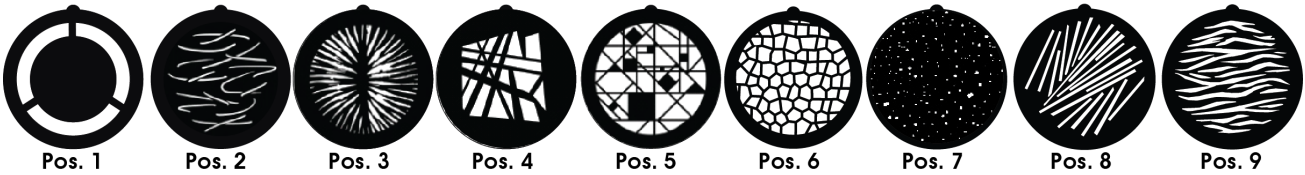

## \*\*IMPORTANT NOTICE REGARDING GOBO DIMENSIONS AND CUSTOM GOBOS

OD = Outside Diameter | ID = Image Diameter

Due to varying manufacturing processes, it is highly recommended to provide a gobo and holder sample from the fixture to 3rd party custom gobo vendors for accurate sizing.

## DIMENSIONAL DRAWINGS

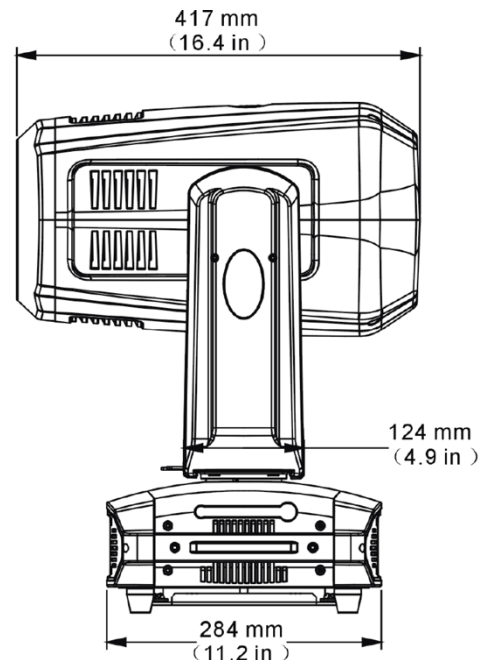
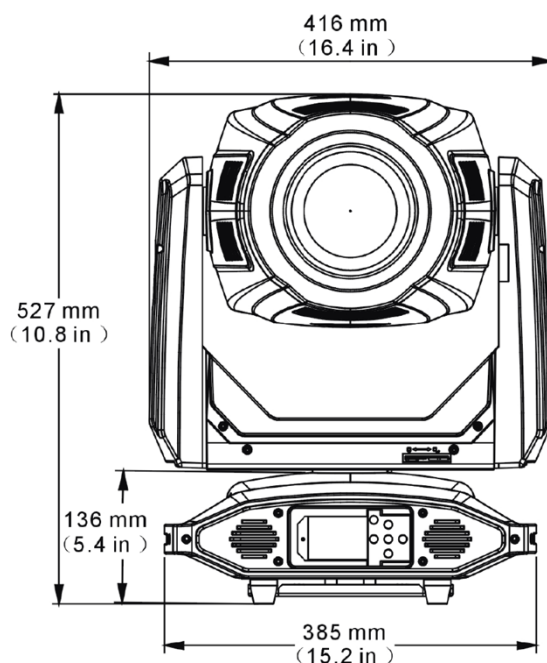

Specifications and improvements in the design of this unit and this manual are subject to change without any prior written notice.

## **FCC STATEMENT**

This device complies with Part 15 of the FCC Rules. Operation is subject to the following two conditions: (1) this device may not cause harmful interference, and (2) this device must accept any interference received, including interference that may cause undesired operation.

## **FCC RADIO FREQUENCY INTERFERENCE WARNINGS & INSTRUCTIONS**

This product has been tested and found to comply with the limits as per Part 15 of the FCC Rules. These limits are designed to provide reasonable protection against harmful interference in a residential installation. This device uses and can radiate radio frequency energy and, if not installed and used in accordance with the included instructions, may cause harmful interference to radio communications. However, there is no guarantee that interference will not occur in a particular installation. If this device does cause harmful interference to radio or television reception, which can be determined by turning the device off and on, the user is encouraged to try to correct the interference by one or more of the following methods:

- Reorient or relocate the device.
- Increase the separation between the device and the receiver.
- Connect the device to an electrical outlet on a circuit different from which the radio receiver is connected.
- Consult the dealer or an experienced radio/TV technician for help.

## **OPTIONAL ACCESSORIES**

<b>ORDER CODE</b>	<b>ITEM</b>
TRIGGER CLAMP	Heavy Duty Wrap Around Hook Style Clamp
SCABLE60	Safety Cable 24" (610mm) 60 lbs. (27kg) Rating
DRCVINCI	Dual Road Case for ARTISTE DAVINCI
EFL001	E-FLY™ External Wireless DMX Transceiver
AC5PDMX5PRO	5 ft. (1.5m) 5pin PRO DMX Cable
CAT6PRO5	5 ft. (1.5m) CAT6 EtherCON Cable
NEU088	3 ft. (1m) powerCON TRUE1 Power Link Cable
	Additional Cable Lengths Available

